

EC MACHINE DIRECTIVE COMPLIANCE DECLARATION

(DIRECTIVE 89/392 EEC, APPENDIX II, PART B)

Manufacturer: FAAC S.p.A.

Address: Via Benini, 1 40069 - Zola Predosa BOLOGNA-ITALY

Hereby declares that:

the 615 automation system

- is intended to be incorporated into machinery, or to be assembled with other machinery to constitute machinery in compliance with the requirements of Directive 89/392 EEC, and subsequent amendments 91/368 EEC, 93/44 EEC and 93/68 EEC;
- complies with the essential safety requirements in the following EEC Directives:

73/23 EEC and subsequent amendment 93/68 EEC.
89/336 EEC and subsequent amendments 92/31 EEC and 93/68 EEC.

and furthermore declares that unit must not be put into service until the machinery into which it is incorporated or of which it is a component has been identified and declared to be in conformity with the provisions of Directive 89/392 EEC and subsequent amendments enacted by the national implementing legislation.

Bologna, 1 January 2000

Managing Director

A. Bassi



IMPORTANT NOTICE FOR THE INSTALLER

GENERAL SAFETY REGULATIONS

- WARNING! FAAC strongly recommends to follow these instructions literally for the safety of persons. Improper installation or misuse of the product will cause very serious damages to persons.**
- Packaging material (plastic, polystyrene etc.) is a potential hazard and must be kept out of reach of children.
- Read the instructions carefully before installing the product.
- Keep these instructions for future reference.
- This product has been designed and manufactured only for the use stated in this manual. Any other use not expressly set forth will affect the reliability of the product and/or could be source of hazard.
- FAAC S.p.A. cannot be held responsible for any damage caused by improper use or different from the use for which the automation system is destined to.
- Do not use this device in areas subject to explosion: the presence of flammable gas or fumes is a serious hazard.
- The system must be constructed in compliance with the following Standards: EN12604, EN12605, EN12453, EN12445 with the exception of vehicles only systems which, however, must be provided with signs specifying use for vehicles only.
For non-EU countries, to obtain an adequate level of safety, the Standards mentioned above must be observed, in addition to national legal regulations.
- FAAC cannot be held responsible for failure to observe technical standards in the construction of gates and doors, or for any deformation of the gates which may occur during use.
- Before carrying out any operations, turn off the system's main switch.
- An omnipowerswitch shall be provided for the installation with an opening distance of the contacts of 3 mm or more. Alternatively, use a 6A thermomagnetic breaker with multi-pole switching.
- Ensure that there is a differential switch up-line of the electrical system, with a trip threshold of 0.03A.
- Check that the earthing plant is in perfect condition and connect it to the metallic parts. Also earth the yellow/green wire of the operator.
- The automation is fitted with an anti-crush safety system that is a torque control device. In any case, further safety devices shall be installed.
- The safety devices (e.g. photocells, safety edges, etc.) protect areas where there is a **mechanical movement hazard, e.g. crushing, entrapment and cutting.**
- Each installation must be fitted with at least one flashing light (e.g. FAAC LAMP, MINILAMP etc) as well as a warning plate suitably fixed to the gate, besides the safety devices as per point 15. above.
- FAAC cannot be held responsible regarding safety and correct functioning of the automation in the event that parts other than FAAC original parts are used.
- Use only FAAC original spare parts for maintenance operations.
- Do not carry out any modifications to automation components.
- The installer must supply all information regarding manual operation of the system in the event of an emergency and provide the end-user with the leaflet attached to the product.
- Keep out of persons when the product is in operation.
- Keep out of reach of children the remote radio controls and any control devices. The automation could be operated unintentionally.
- The end-user must avoid any attempt to repair or adjust the automation personally. These operations must be carried out exclusively by qualified personnel.
- 24) What is not explicitly stated in these instructions is not permitted.**

615 AUTOMATIC SYSTEM

The 615 automatic system consists of an aluminium beam with reflex reflectors, and a steel upright subjected to cataphoresis treatment and painted with polyester paint. The upright houses the hydraulic operator and is designed also to house the electrical control equipment. The operator, which moves the beam, consists of a hydraulic pump unit and a double-acting cylinder.

The system is supplied with an adjustable anti-crushing protection safety device. It also includes a device stopping the beam in any position, and a manual release command for use in case of power cuts or faults.

The beam balancing spring and the electronic control unit (not supplied) must be ordered with reference to the sales price list.

The 615 automatic system was designed and built for controlling vehicle access. Do not use for any other purpose.

1. DESCRIPTION AND TECHNICAL SPECIFICATIONS

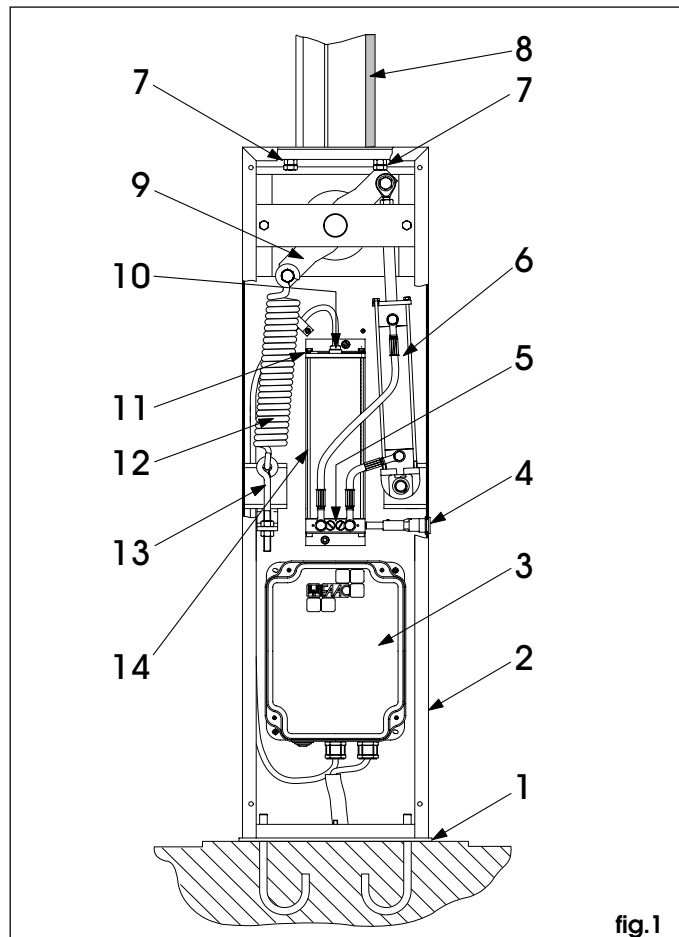

fig.1

- | | |
|---------------------------------------|-----------------------------|
| ① foundation plate | ⑧ beam |
| ② barrier upright | ⑨ equaliser |
| ③ electronic equipment (not supplied) | ⑩ oil filling plug |
| ④ emergency release | ⑪ breather screw |
| ⑤ torque adjustment screws | ⑫ balancing spring |
| ⑥ double-acting piston | ⑬ spring adjustment tie-rod |
| ⑦ stroke limit screw | ⑭ hydraulic pump unit |

TABLE 1 Technical specifications of "615 barrier"

BARRIER MODEL	615-1,5l/min	615-3l/min
Beam max. length (m)	5	2,5
Max. opening time (sec)	5,7	2,9
Angle speed (rad/sec)	0,28	0,54
Pump flow-rate (l/min)	1,5	3
Max. torque (Nm)	400	300
Types of beam	Rigid/Skirt Articulated	Rigid
Use frequency (at 20°C)	50%	40%
Max.consecutive cycles (at 20°C)	220	340
Power supply	230V~ (+6 -10 %) 50Hz	
Absorbed power (W)	220	
Type of oil	FAAC XD 220	
Oil quantity (Kg)	0,9	
Winding thermal protection	120°C	
Anti-crushing protection system	standard by-pass valves	
Ambient temperature	-20 to +55 °C	
Hood protective treatment	cataphoresis	
Hood paint	Polyester RAL 2004	
Protection class	IP 44	
Weight (Kg)	34 (sale package)	
Upright overall dimensions LxHxD(mm)	270 x 1015 x 140	
Electric motor technical specifications		
RPM	1400	2800
Capacity (W)	220	
Absorbed current (A)	1	
Power supply	230V~ (+6 -10 %) 50Hz	

1.1. MAXIMUM USE CURVE

The curve makes it possible to establish maximum work time (T) according to use frequency (F).

E.g. The 615 automatic system can operate non-stop at a use frequency of 50%.

To ensure efficient operation, operate in the work range below the curve.

Important: The curve is obtained at a temperature of 20°C. Exposure to the direct sunlight can reduce use frequency down to 20%.

Calculation of use frequency

The percentage of effective work time (opening + closing) compared to cycle total time (opening + closing + pause times).

Calculation formula:

$$\%F = \frac{Ot + Ct}{Ot + Ct + Pt + It} \times 100$$

where:

- Ot = opening time
- Ct = closing time
- Pt = pause time
- It = interval time between a full cycle and the next.

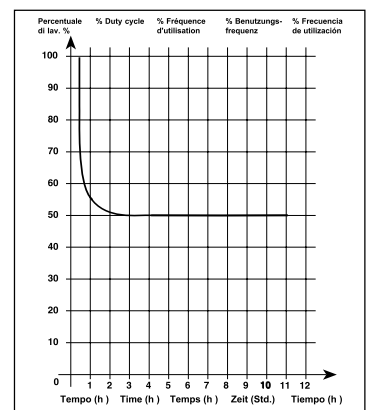

2. ELECTRICAL DEVICES (standard system)

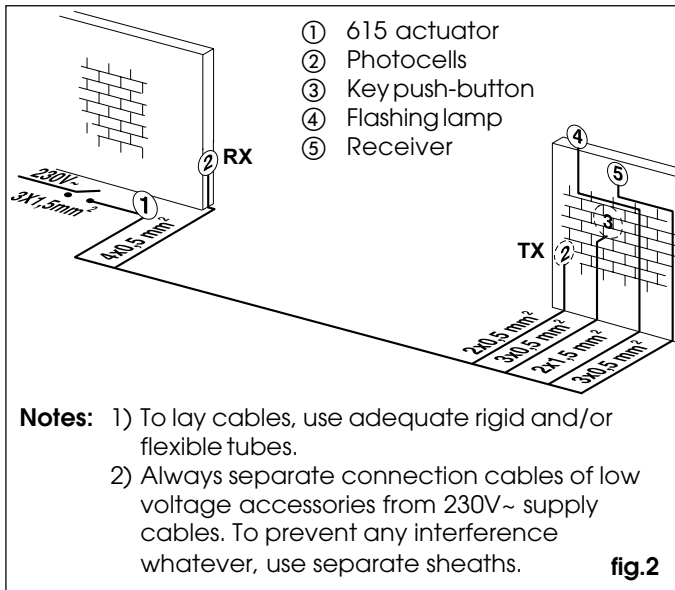

3. DIMENSIONS

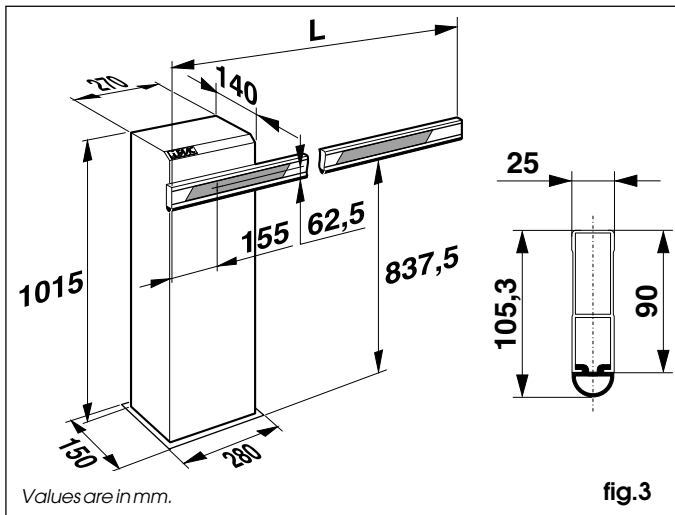

4. INSTALLING THE AUTOMATIC SYSTEM

4.1. PRELIMINARY CHECKS

To ensure safety and an efficiently operating automatic system, make sure the following conditions are observed:

- When moving, the beam must not, on any account, meet any obstacles or aerial voltage cables.
- The soil must permit sufficient stability for the foundation plinth.
- There must be no pipes or electric cables in the plinth excavation area.
- If the barrier body is exposed to passing vehicles, install, if possible, adequate means of protection against accidental impact.
- Check if an efficient earth socket is available for connection to the upright. Use the supplied nuts and washer (fig. 5 ref.B).

4.2. MASONRY FOR FOUNDATION PLATE

- 1) Make a foundation plinth as shown in fig.4 (referred to clayey soil)
- 2) Wall the foundation plate as shown in fig.4, supplying one or more sheaths for routing electric cables. Using a spirit level, check if the plate is perfectly level. Wait for the cement to set.

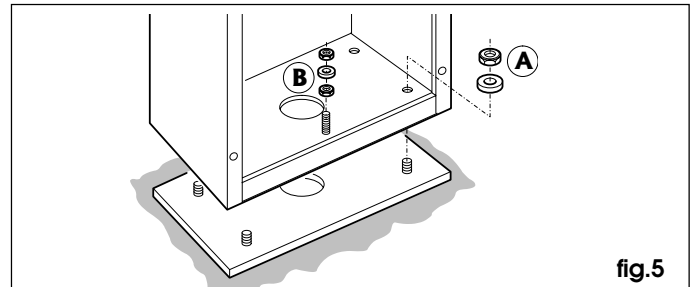
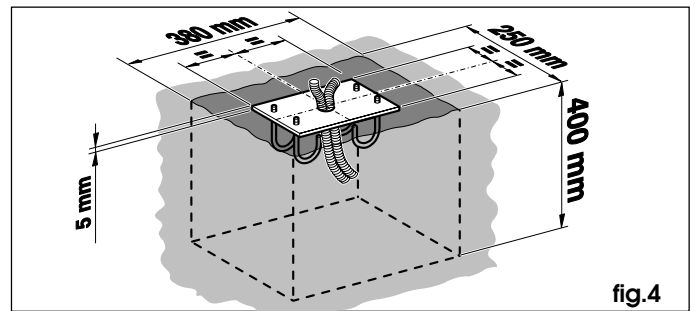

4.3. MECHANICAL INSTALLATION

- 1) Remove the cover, provisionally unscrewing the screws securing it to the upright.
- 2) Using the four nuts and washers supplied, secure the upright to the foundation plate (fig.5 ref.A). Remember that the upright door should normally face the building.
- 3) Decide whether the installation is right-hand (Fig. 7/A) or left-hand (Fig. 7/B) in connection with the references below. **ATTENTION: The 615 automated system is always supplied in the right-hand version - for left-hand installation, see chapter 4.5.** Make sure that the piston rod fitted on the rocker arm is fully extended (corresponding to the beam's vertical position).
- 4) Remove and store the breather screw as shown in fig.9 ref.A.
- 5) Assemble the flange (fig.6-ref.1) vertically on the shaft (Fig.6-ref 2). Position the centring bush (Fig.6-Ref.3) on the shaft (Fig.6-ref 2). Tighten the screw and spring washer (Fig.6-ref 4) exercising sufficient force to make the flange (fig.6-ref 1) slide along the shaft until the bush is in contact with the shaft. **N.B:** Tightening requires considerable force as the flange is secured on the hexagonal shaft by interference.
- 6) Assemble the beam (Fig.6-ref 6) positioning it vertically on the flange (fig.6-ref 1) and securing it with the supplied screws.
- 7) Fit the hole cap (fig.6 ref.5)
Install and adjust the balancing spring.

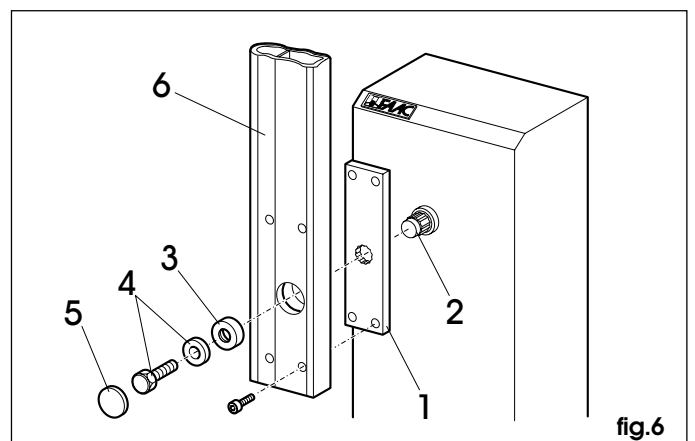

4.4. INSTALLING AND ADJUSTING THE BALANCING SPRING

4.5. CONVERTING FROM RIGHT-HAND TO LEFT-HAND VERSION

- 1) Check if the balancing spring matches the type of beam installed: see chapter 8.
- 2) Take the tie-rod support bracket (fig.7 ref.1) from the supplied package, and assemble it on the seat on the barrier body, using the self-locking nut (fig.7 ref.2) and an appropriate washer.
- 3) Take the bronze bush (fig.7 ref.3) from the same package, fit it on the spring (fig.7 ref.6) and secure it to the rocker arm with M10 screw and washer (fig.7 ref.4).
- 4) Keeping the beam always vertical, assemble the tie-rod (fig.7 ref.5) to the bracket (fig.7 ref.1) already fitted, and then fit the spring (fig.7 ref.6).
- 5) Release the operator (see chapter 6) and position the beam at 45°, then adjust the tie-rod and set the spring until the weight of the beam is balanced in that position.
- 6) Tighten the two nuts securing the tie-rod to the upright.
- 7) Restore normal operation as described in chapter 7.

Procedure for converting a right-hand version to left-hand.
Release the operator.

Loosen the connection (fig.7 ref.A)

Provisionally remove the screw securing the piston (fig. 8 ref.B) and the seeger ring (fig.8 ref.C).

Turn the rocker arm.

Position the piston on the left and secure it with the screw (fig.8 ref.D) and seeger ring (fig.8 ref.E) you had previously removed.

Tighten the connection (fig.8 ref.F).

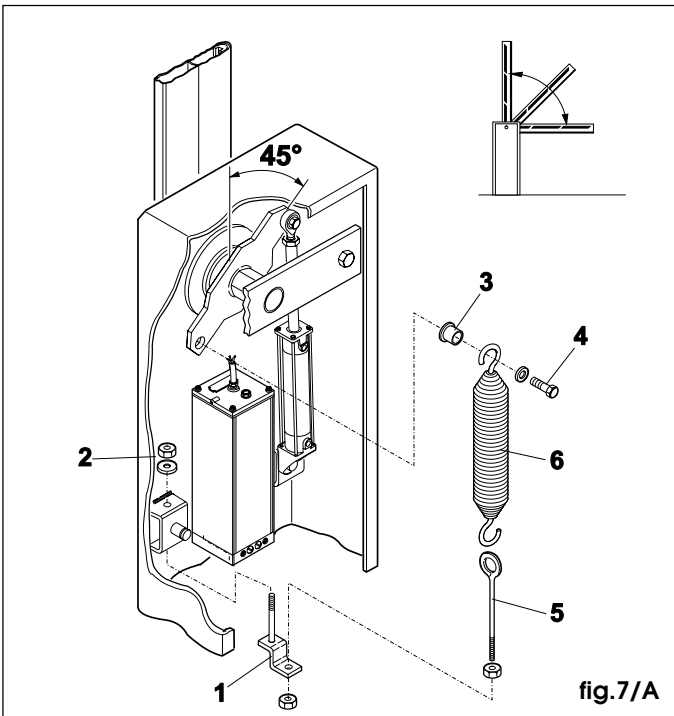

fig.7/A

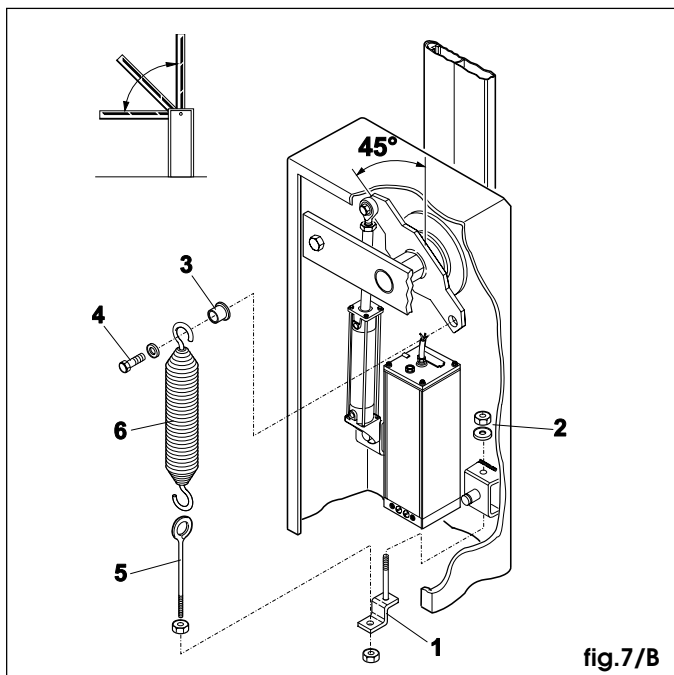

fig.7/B

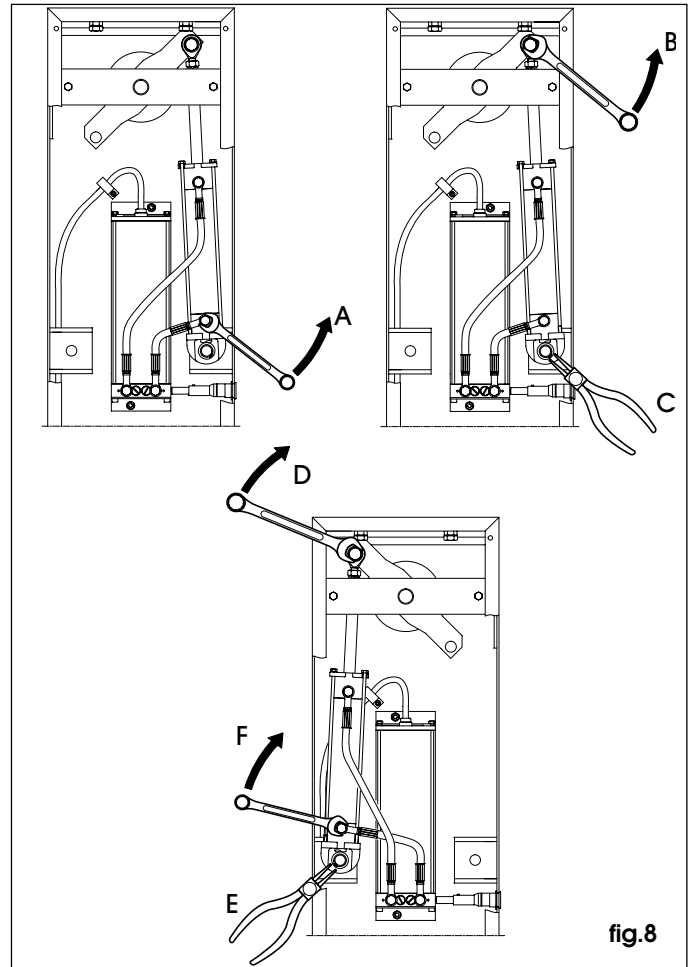

fig.8

5. START-UP

5.1. CONNECTION TO ELECTRONIC EQUIPMENT

The electrical equipment must be ordered separately. Install the electronic control unit, observing the instructions supplied with it.

5.2. ADJUSTING TRANSMITTED TORQUE

To set the hydraulic system controlling transmitted power, turn the two by-pass screws (fig.9 ref.B).

The red screw controls closing movement torque.

The green screw controls opening movement torque.

To increase torque, turn the screws clockwise.

To reduce torque, turn the screws anti-clockwise.

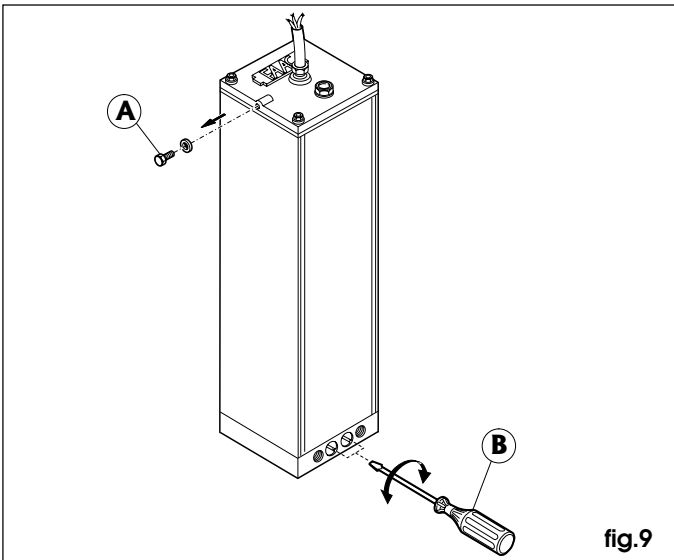

fig.9

5.3. ADJUSTING THE MECHANICAL STROKE LIMITERS

Adjust the position of the beam to maximum closing and opening positions, using the stroke limit mechanical stops as shown in fig.10.

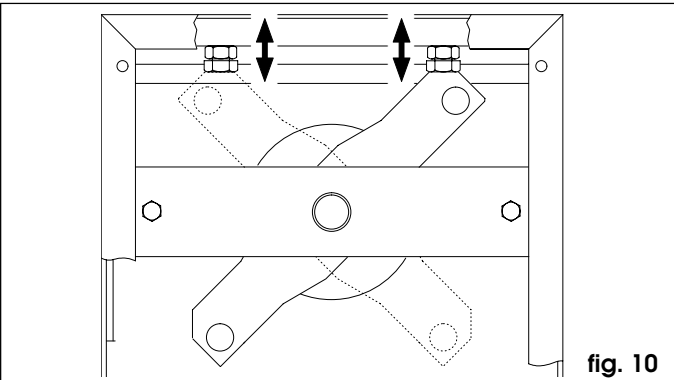

fig. 10

5.4 AUTOMATION TEST

After installation, apply the danger warning sticker on the top of the upright (Fig 11). Check operating efficiency of the automatic system and all accessories connected to it. Hand the "User's Manual" to the Client, explain correct operation and use of the barrier, and indicate the potentially dangerous areas of the automatic system.

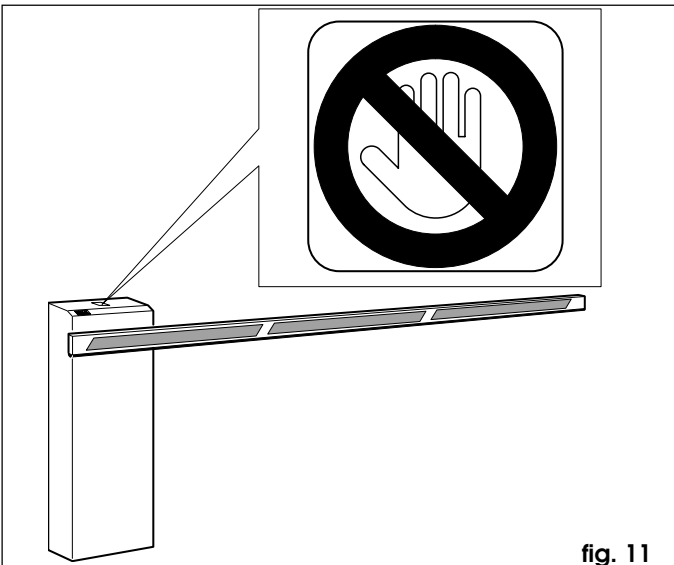

fig. 11

6. MANUAL OPERATION

If the barrier has to be moved manually due to a power cut or fault of the automatic system, use the release device as follows:

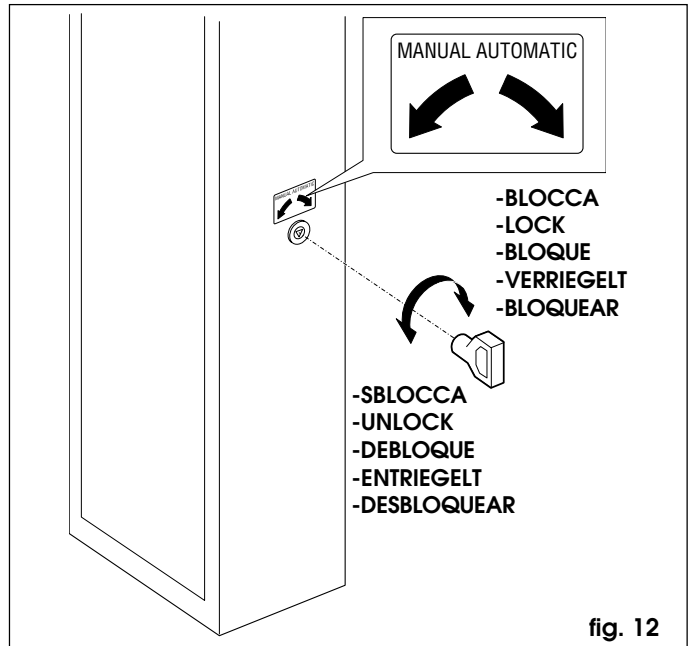

fig. 12

- Fit the standard triangular key (Fig. 12) in the lock and turn it **anti-clockwise** through 1 turn.
- Open and close the barrier manually.

7. RESTORING NORMAL OPERATION MODE

To prevent an involuntary pulse from activating the barrier during the manoeuvre, before restoring normal operation, switch off power to the system, and turn the triangular key **clockwise** until it stops, and then remove it.

8. BALANCING SPRINGS

The 615 automatic system requires a balancing spring, which must be ordered separately. The spring varies according to length and type of beam (rigid, skirt or articulated).

Consult the tables below to see if the spring matches.

8.1. SPRINGS FOR RIGID AND SKIRTED BEAMS

Tab. 2

BALANCING SPRING				
Ø	rigid beam	Light beam	skirted beam	code
4.5		1.50 ÷ 2.50m		721128
5		2.51 ÷ 3.00m		721127
5.5	1.50 ÷ 2.50m	3.01 ÷ 3.50m	1.50 ÷ 2.00m	721008
6		3.51 ÷ 4.00m	2.01 ÷ 2.50m	721005
6.5	2.51 ÷ 3.00m		2.51 ÷ 3.00m	721013
7	3.01 ÷ 4.00m			721006
7.5			3.01 ÷ 4.00m	721007
8	4.01 ÷ 5.00m			721018
8.5			4.01 ÷ 5.00m	721022

9. AVAILABLE ACCESSORIES

SKIRT KIT (fig.13)

The skirt kit increases visibility of the beam. It is available in lengths from 2 m to 3 m. **IMPORTANT:** If a skirt kit is installed, the balancing spring must be adapted.

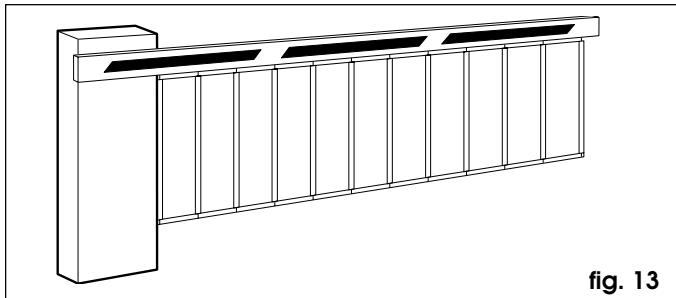

fig. 13

FORK SUPPORT (fig.14)

The fork has two functions:
 - it prevents the beam, when closed, from bending and splitting if its end is stressed by extraneous forces.
 - it allows the beam to rest when closed and thus prevents the profile bending downward.

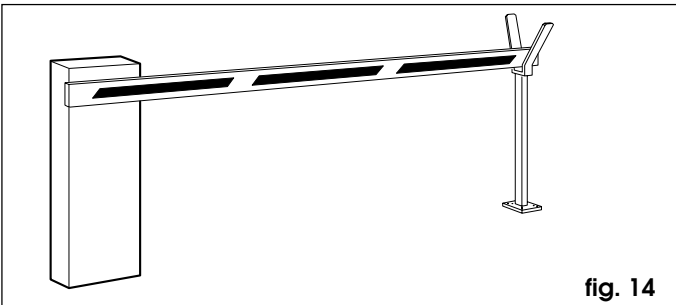

fig. 14

ARTICULATION KIT (fig.15)

The articulation kit makes it possible to articulate a rigid beam to a maximum ceiling height of 3 m. **IMPORTANT:** If an articulation kit is installed, the balancing spring must be adapted.

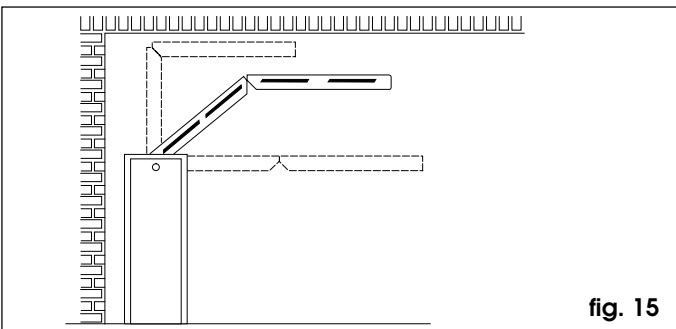
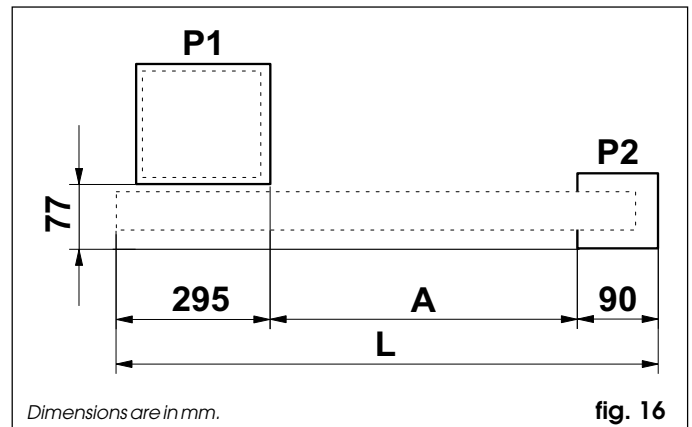

fig. 15

POSITIONING THE FORK SUPPORT FOUNDATION PLATE



Dimensions are in mm.

fig. 16

To position the fork support foundation plate, refer to fig. 16 where:

- P1 = barrier foundation plate
- P2 = fork support foundation plate
- L = beam length (in mm)
- A = L-385 (in mm)

10. MAINTENANCE

Whenever doing maintenance, always check correct settings of the by-pass screws, system balancing, and efficiency of safety devices.

10.1. TOPPING UP OIL

Periodically check quantity of oil inside the tank. An annual check is sufficient for low to medium use frequency; for heavier duty, check every 6 months. The level must not fall below the low mark on the stick (fig.17). To top-up, unscrew the filling plug (fig. 17) and pour oil to MAX level on the stick. Use only FAAC XD 220 oil and no other.

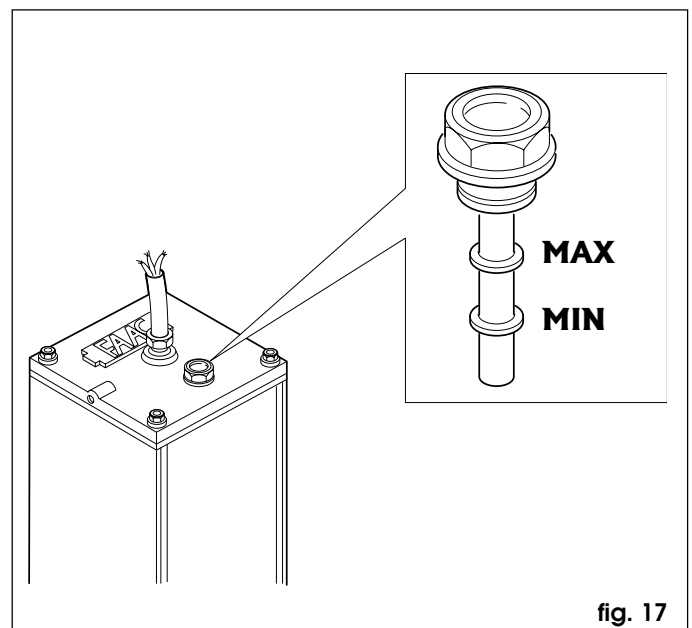

fig. 17

11. REPAIRS

For repairs, contact FAAC's authorised Repair Centres.

User's operating manual

615 AUTOMATIC SYSTEM

GENERAL SAFETY REGULATIONS

If correctly installed and used, the 615 automatic system ensures a high degree of safety.

Some simple rules on behaviour can prevent accidental trouble:

- Do not pass under the beam when it is moving. Wait for the beam to open fully before passing under it.
- Do not, on any account, stay under the beam.
- Do not stay near the automatic system, and do not allow children, persons or things to do so, especially when it is operating.
- Keep radio controls or other pulse generators away from children, to prevent the automatic system from being activated involuntarily.
- Do not allow children to play with the automatic system.
- Do not willingly obstruct beam movement.
- Prevent any branches or shrubs from interfering with beam movement.
- Keep indicator-lights efficient and easy to see.
- Do not attempt to activate the beam by hand unless you have released it.
- In the event of malfunctions, release the beam to allow access and wait for qualified technical personnel to do the necessary work.
- When you have set manual operation mode, cut power to the system before restoring normal operation.
- Do not in any way modify the components of the automation system.
- Do not attempt any kind of repair of direct action whatever and contact qualified personnel only.
- At least every six months: arrange for qualified personnel to check the automatic system, safety devices and earth connection.

DESCRIPTION

The 615 automatic system is an ideal barrier for controlling vehicle access areas up to 5 m in width and of medium transit frequency.

The hood contains a hydraulic pump unit, a double-acting cylinder, and the beam balancing spring.

The beam consists of an aluminium profile with red reflex reflectors so it can easily be seen even in the dark.

Barrier operation is controlled by a electronic control unit housed in an enclosure with adequate degree of protection against atmospheric agents, and which can be housed inside the hood.

The beam is normally closed in horizontal position.

When the electronic control unit receives an opening command via the radio control or any other pulse generator, it activates the hydraulic equipment which rotates the beam through 90° until it reaches the vertical position allowing access. If automatic mode was set, the beam closes automatically after selected pause time has elapsed.

If the semi-automatic mode was set, a second pulse must be sent to close the beam.

An opening pulse given during re-closing always reverses movement.

A stop pulse (if supplied) always stops movement.

For details on barrier behaviour in different function logics, consult the installation Technician.

The automatic systems include safety devices (photocells) that prevent the beam from re-closing when there is an obstacle in the area they protect.

The 615 automatic system is supplied (as a standard item) with an anti-crushing protection safety devices which limits the torque transmitted to the beam.

The hydraulic system guarantees the beam is stopped in any position.

Manual opening is, therefore, only possible by using the release system.

The (flashing) indicator-light indicates that the beam is moving.

MANUAL OPERATION

If the barrier has to be moved manually due to a power cut or fault of the automatic system, use the release device as follows:

The supplied key is triangular.

- Fit the triangular key (Fig.1) in the lock and turn it **anti-clockwise** through 1 turn.
- Open and close the barrier manually.

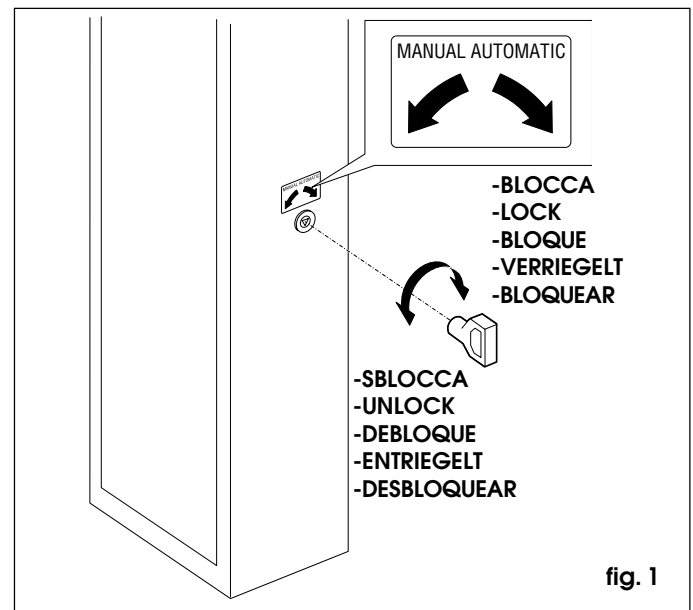

RESTORING NORMAL OPERATION MODE

To prevent an involuntary pulse from activating the barrier during the manoeuvre, before restoring normal operation, switch off power to the system, and turn the triangular key **clockwise** until it stops, and then remove it.